

CV&AS CENTRAL VALLEY ENGINEERING AND SURVEYING	
2016 SECOND STREET SELMA, CA 93662 WWW.CVEAS.COM	Tel. (559) 891-8811 Fax (559) 682-3812 Email: info@cveas.com
DATE OF SURVEY JOB NO. DRAWN BY REVISION DATE DRAWING NAME	10/20/11 11033 ALTA N.SAHOTA ALTA

CIVIL ENGINEERING • LAND SURVEYING • CONSTRUCTION • CUSTOM HOME DESIGN
COMMERCIAL BUILDING DESIGN • PLANNING & PROJECT MANAGEMENT

ALTA/ACSM LAND TITLE SURVEY

COUNTY OF SANTA CRUZ, STATE OF CALIFORNIA

SHEET 4 OF 5

FOUND 3" BRASS CAP MONUMENT
FLUSH PER (R-1) FALLS 0.49'
SOUTHERLY FROM CENTERLINE OF WEST
BEACH ROAD (HELD FOR LEE ROAD
ALIGNMENT)

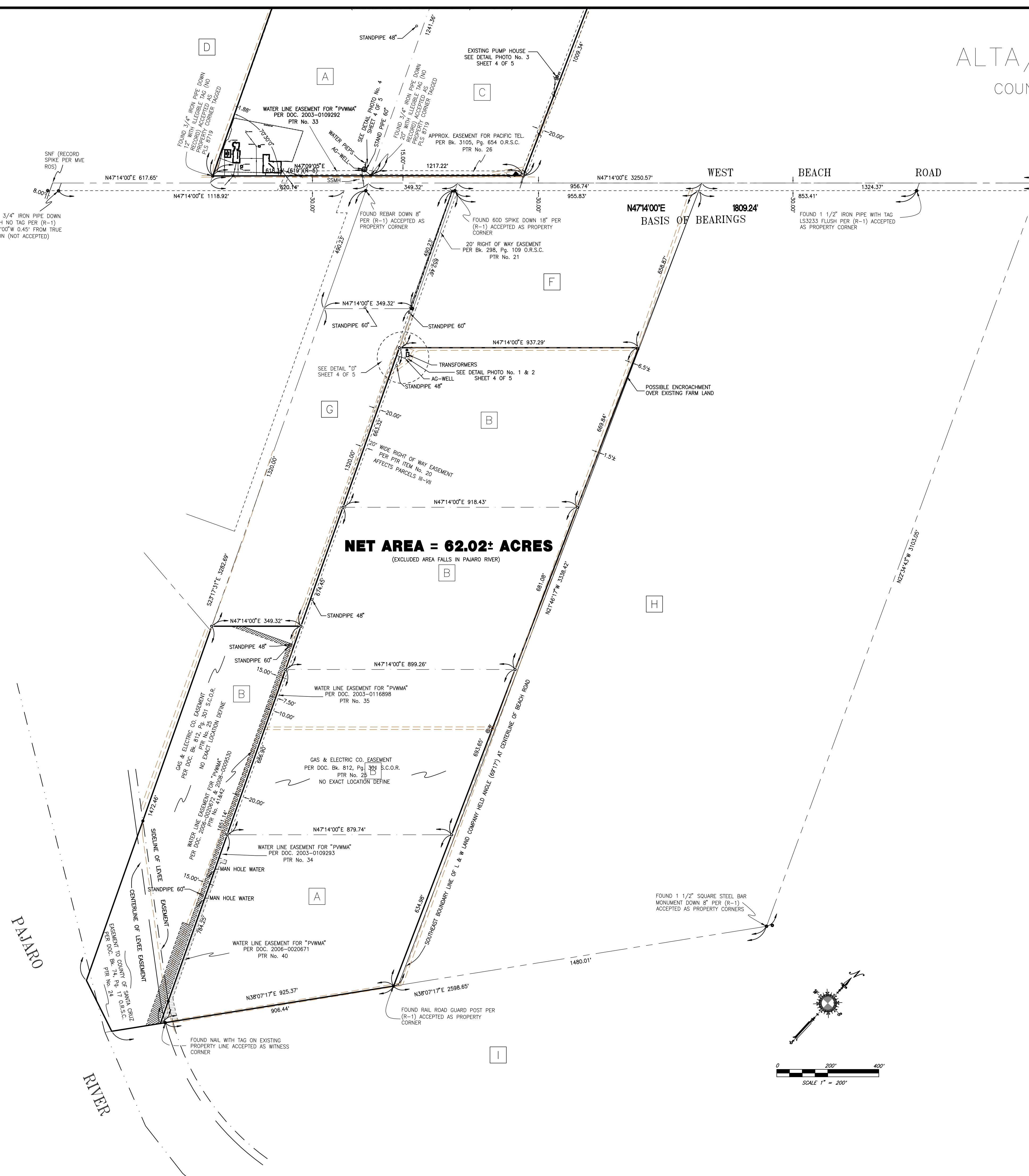

NET AREA = 62.02± ACRES
(EXCLUDED AREA FALLS IN PAJARO RIVER)

DETAIL "D"

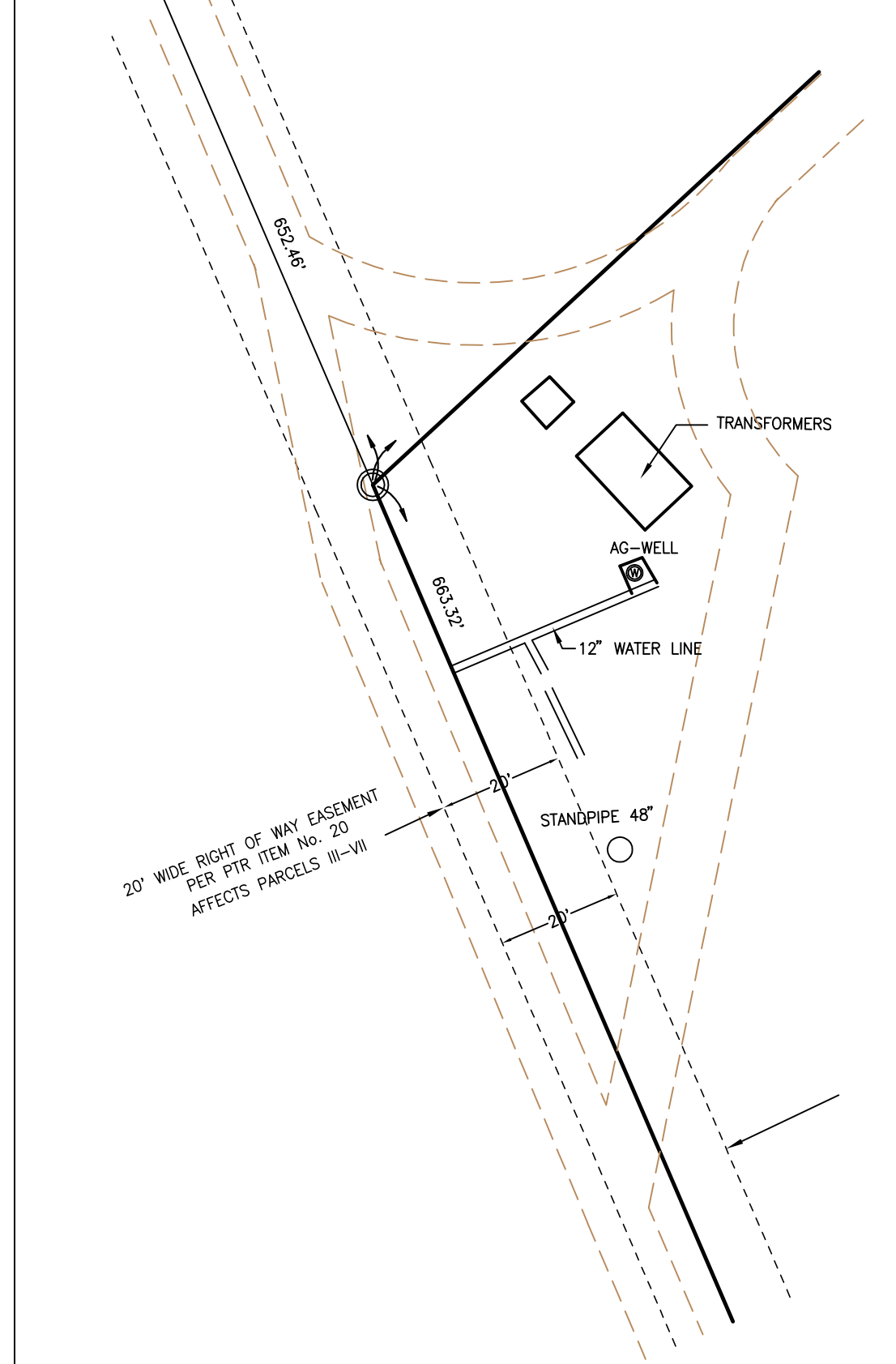

PHOTO No. 1 DATE 10/30/11



PHOTO No. 2 DATE 10/30/11



PHOTO No. 3 DATE 10/30/11



PHOTO No. 4 DATE 10/30/11

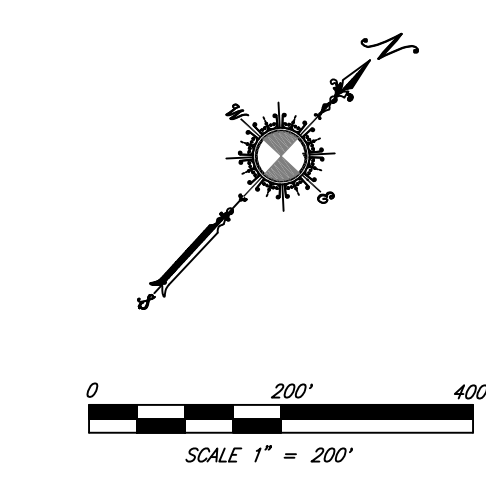

CVEAS CENTRAL VALLEY ENGINEERING AND SURVEYING		DATE OF SURVEY	10/20/11
2016 SECOND STREET SELMA, CA 93662		JOB NO.	11033 ALTA
WWW.CVEAS.COM		DRAWN BY	N.SAHOTA
Tel: (559) 891-8811 Fax: (559) 682-3812 Email: info@cveas.com		REVISION DATE	
CIVIL ENGINEERING • LAND SURVEYING • CONSTRUCTION • CUSTOM HOME DESIGN COMMERCIAL BUILDING DESIGN • PLANNING & PROJECT MANAGEMENT		DRAWING NAME	ALTA

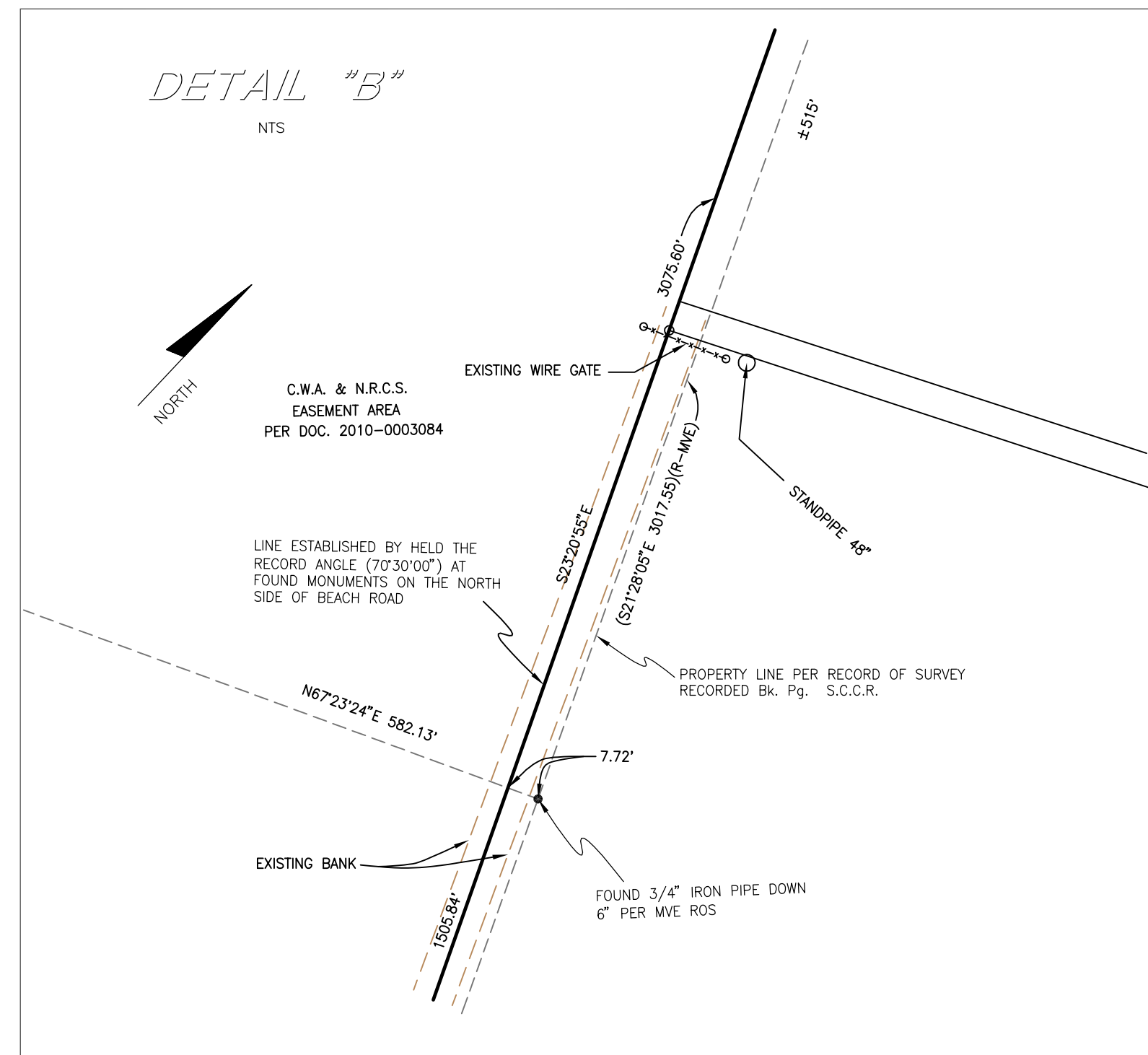

D

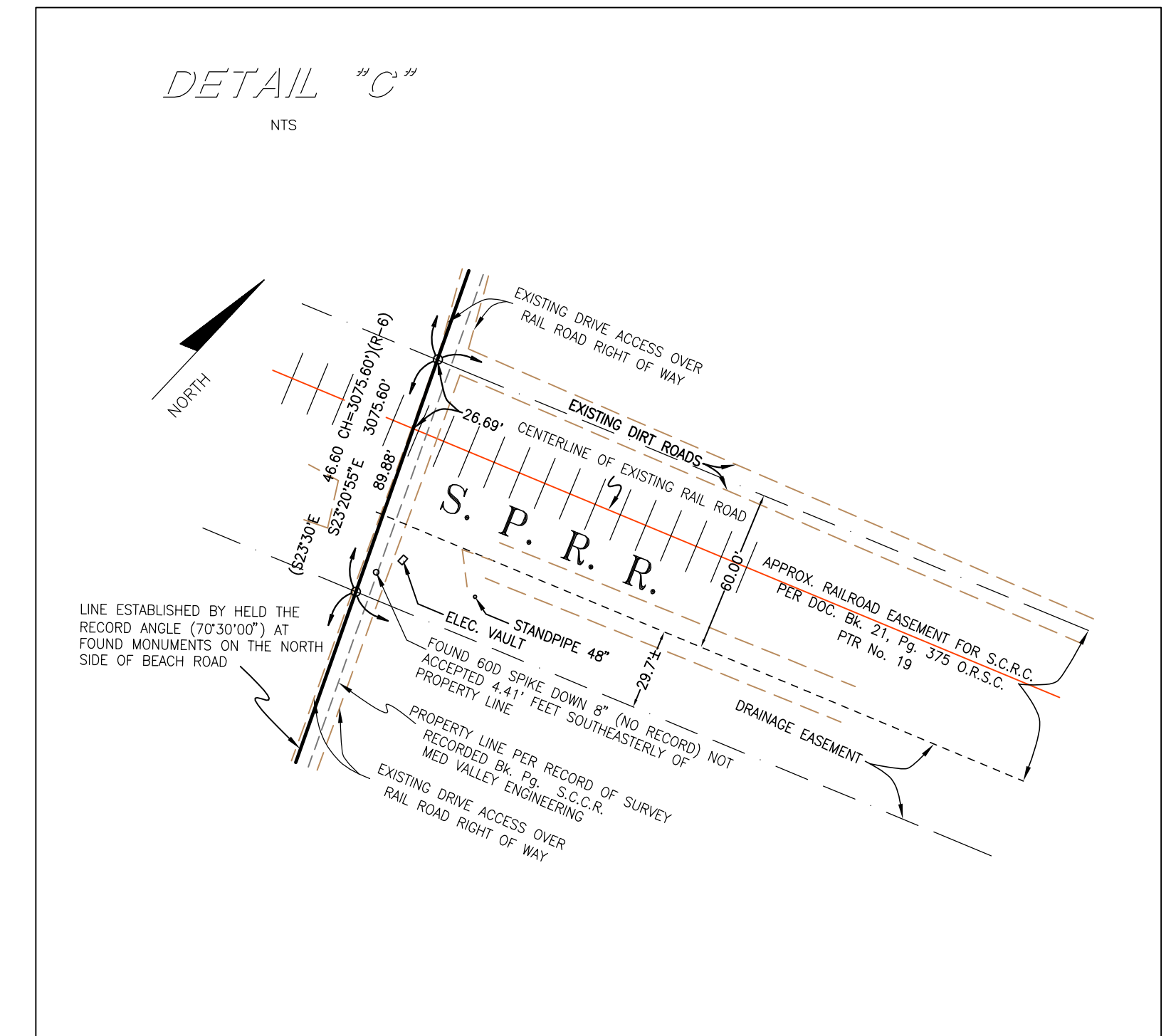

D

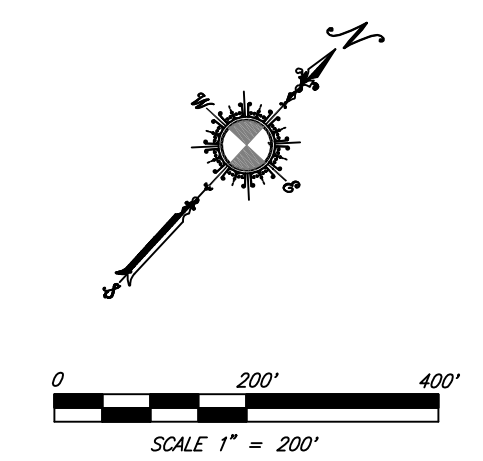
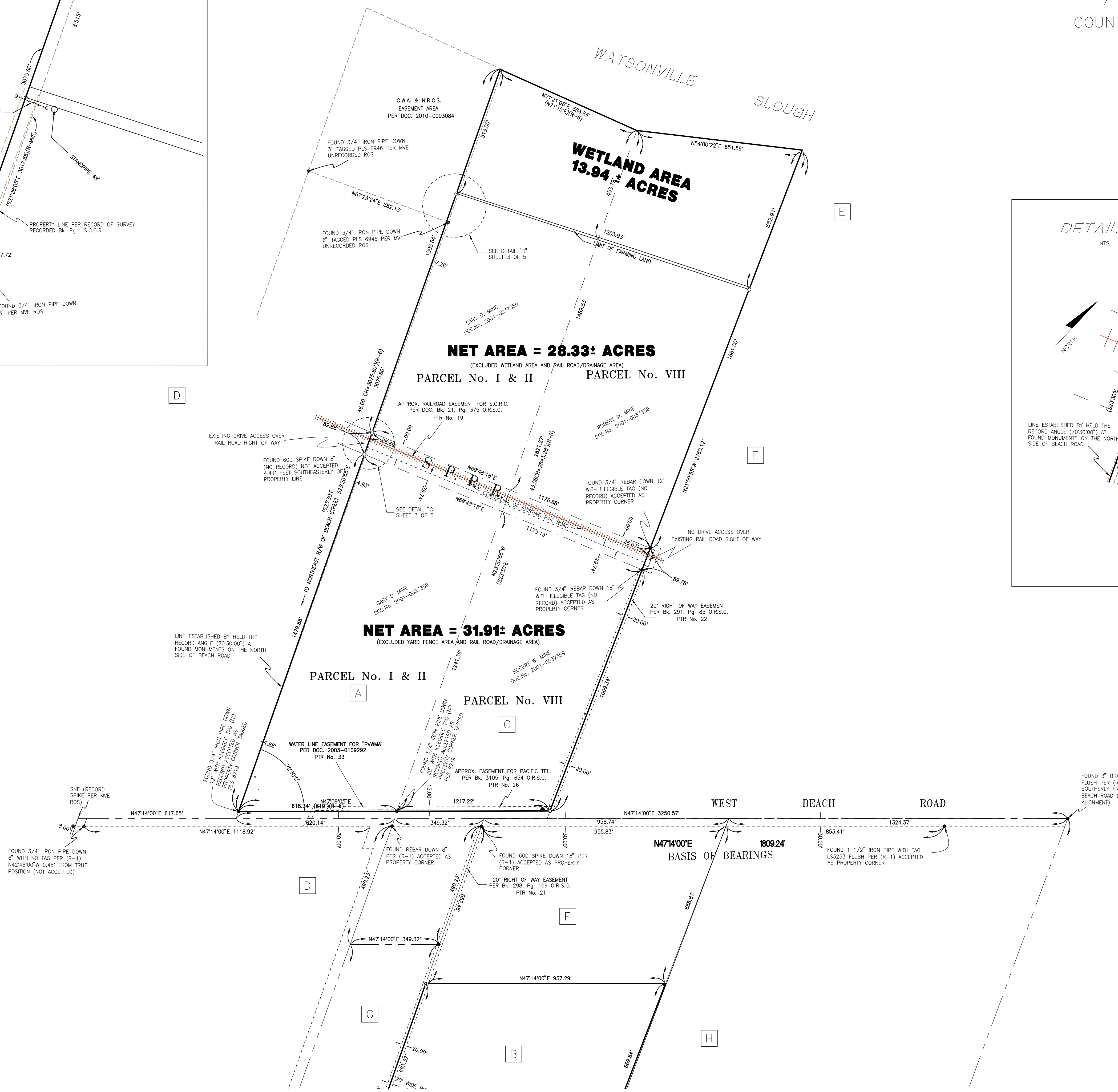

CVEAS CENTRAL VALLEY ENGINEERING AND SURVEYING 2016 SECOND STREET SELMA, CA 93662 WWW.CVEAS.COM	DATE OF SURVEY 10/20/11
	JOB NO. 11033 ALTA
	DRAWN BY N.SAHOTA
	REVISION DATE _____
	DRAWING NAME ALTA
Tel. (559) 891-8811 Fax (559) 682-3812 Email: info@cveas.com	DATE OF SURVEY 10/20/11 JOB NO. 11033 ALTA DRAWN BY N.SAHOTA REVISION DATE _____ DRAWING NAME ALTA

(C) ENGINEERING • LAND SURVEYING • CONSTRUCTION • CUSTOM HOME DESIGN
COMMERCIAL BUILDING DESIGN • PLANNING & PROJECT MANAGEMENT

ALTA/ACSM LAND TITLE SURVEY

COUNTY OF SANTA CRUZ, STATE OF CALIFORNIA

SHEET 2 OF 5

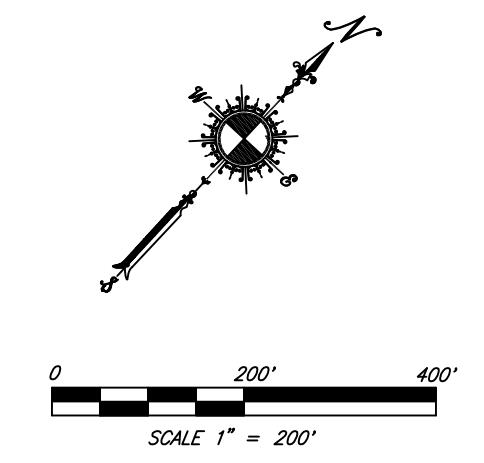
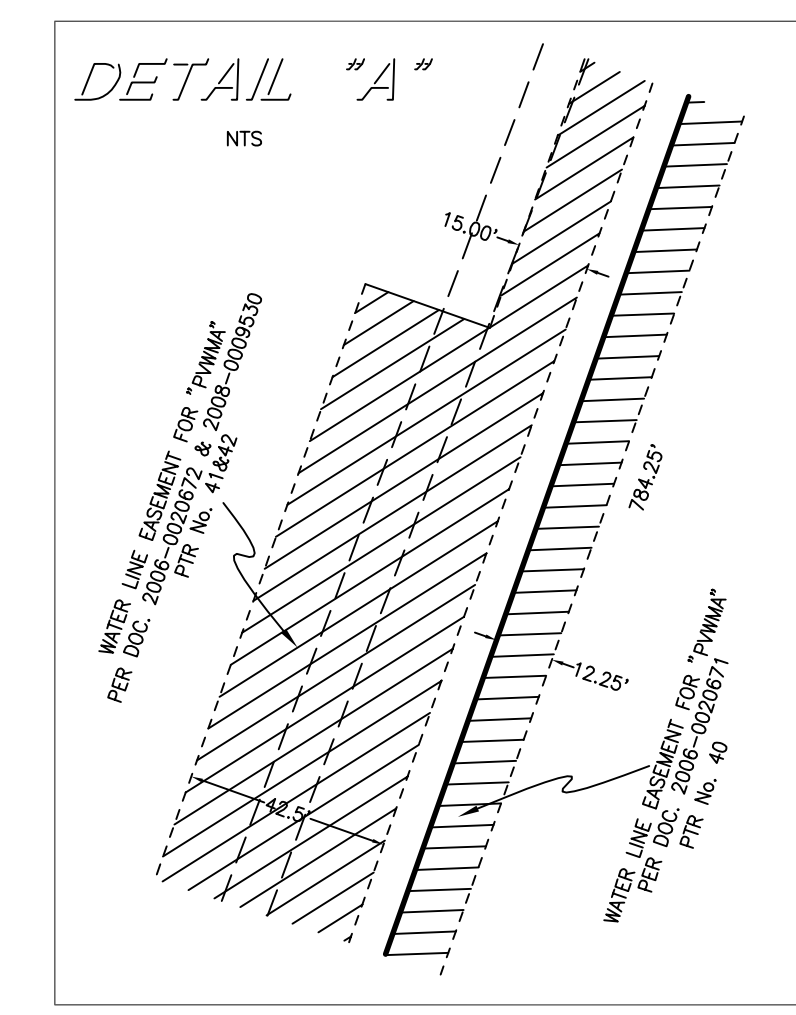
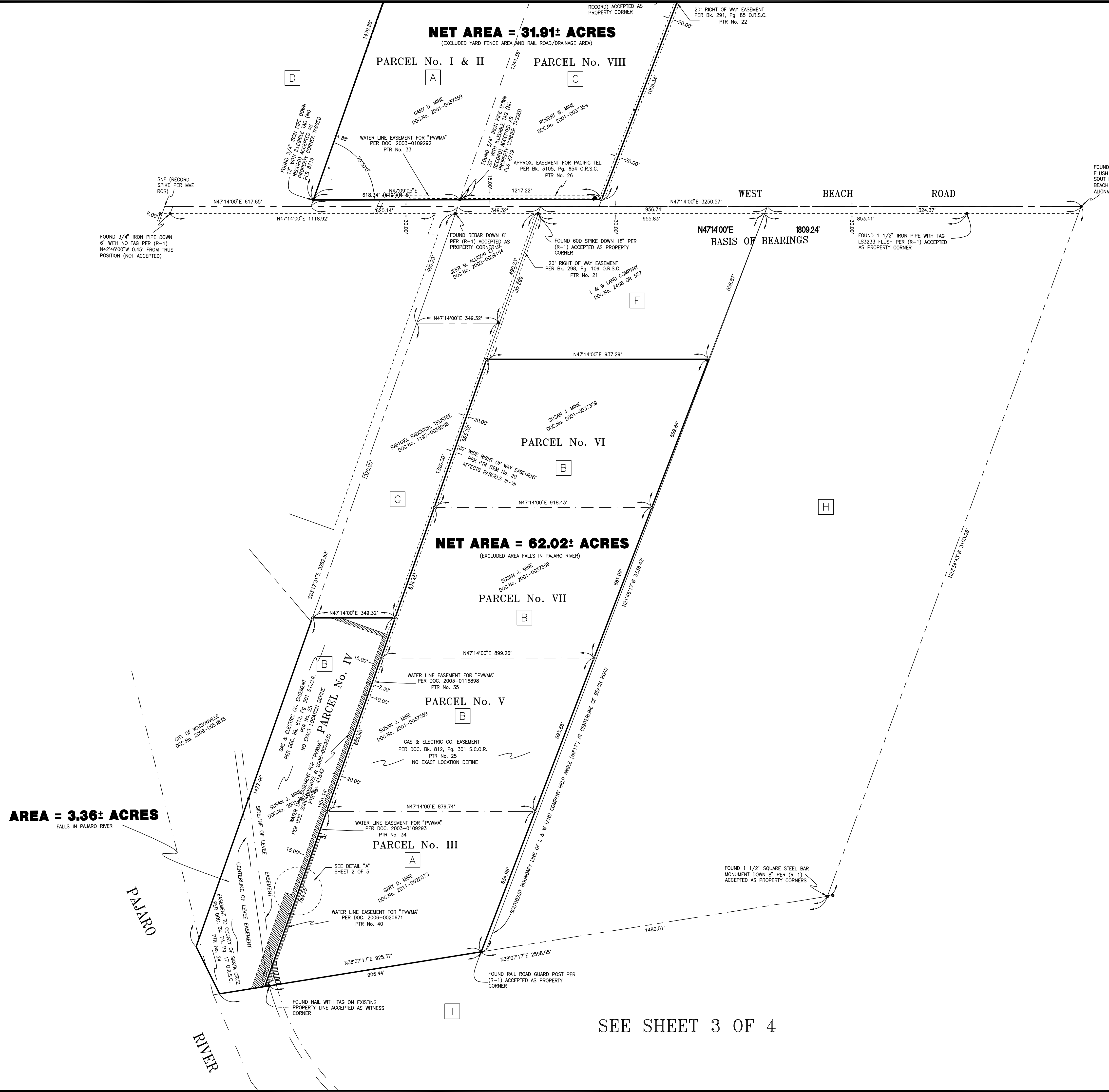

SEE SHEET 3 OF 4

CV&AS CENTRAL VALLEY ENGINEERING AND SURVEYING	DATE OF SURVEY 10/20/11
2016 SECOND STREET SELMA, CA 93662 WWW.CVEAS.COM	JOB NO. 11033 ALTA
Tel. (559) 891-8811 Fax (559) 682-3812 Email: info@cveas.com	DRAWN BY N.SAHOTA
	REVISION DATE
	DRAWING NAME ALTA